

**Description** : Flat Lithium Battery  
**Chemical system** : Lithium Manganese  
**Nominal voltage** : 3 Volts  
**Nominal capacity** : 50mAh  
**Dimensions** :  $\varnothing 16\text{mm} \times 1.6\text{mm}$   
**Shelf life** : 10 years at room temperature  
**Average weight** : 1.1 grams  
**Operation temperature**:  $-20^{\circ}\text{C} \sim 60^{\circ}\text{C}$   
**Storage temperature**:  $20^{\circ}\text{C} \pm 2^{\circ}\text{C}$

### Cross References:

IEC	JIS	Panasonic	Varta
CR1616	CR1616	CR1616	CR1616

### Discharge Characteristics

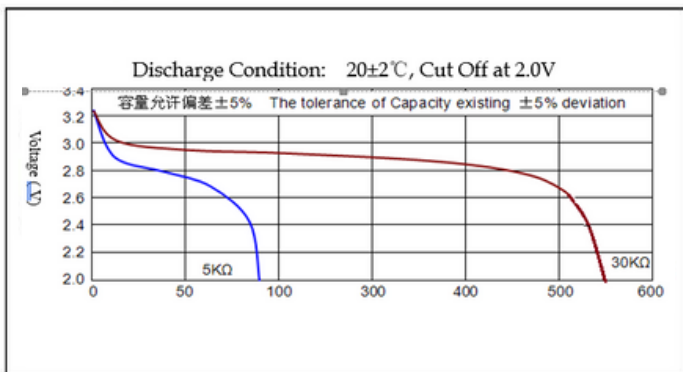

### Pulse discharge characteristics

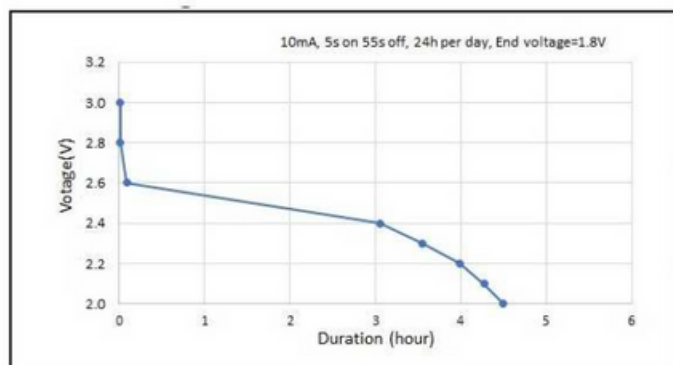

Model no.: **CR1616**

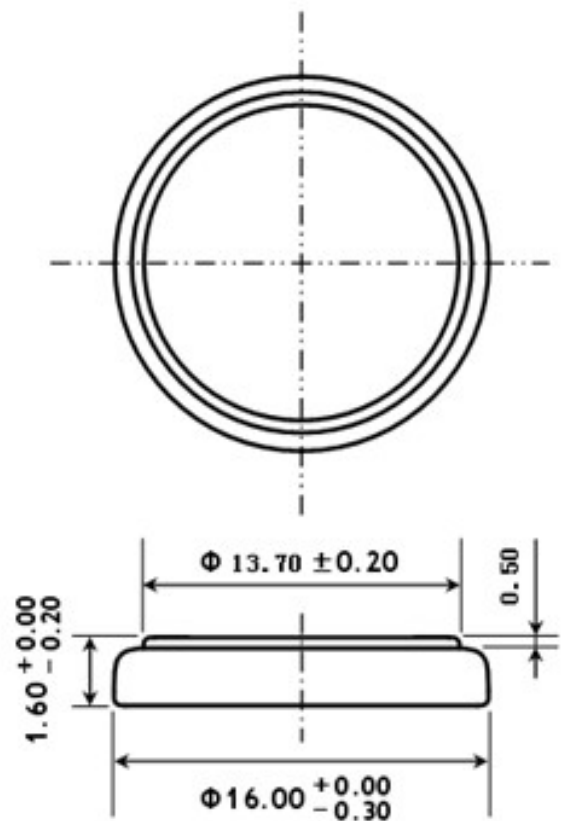

The information (subject to change without prior notice) contained in this document is for reference only and should not be used as a basis for product guarantee or warranty. For applications other than those described here, please consult your nearest GP Sales and Marketing Office or Distributors.